



TAI-SAW TECHNOLOGY CO., LTD.

No. 3, Industrial 2nd Rd., Ping-Chen Industrial District,
Taoyuan, 324, Taiwan, R.O.C.

TEL: 886-3-4690038 FAX: 886-3-4697532

E-mail: tstsales@mail.taisaw.com Web: www.taisaw.com

Approval Sheet For Product Specification

Issued Date: 06/28/2005

Product Name: HC49-SMD 8.000MHz Crystal Resonator

TST Part No.: TZ0696A

Customer Part No.: _____

Company: _____
Division: _____
Approved by : _____
Date: _____

Checked by: _____ Robert Chang

Approved by: _____ TF Yang

Date: _____ 06/28/2005



TAI-SAW TECHNOLOGY CO., LTD.

No. 3, Industrial 2nd Rd., Ping-Chen Industrial District,
Taoyuan, 324, Taiwan, R.O.C.

TEL: 886-3-4690038 FAX: 886-3-4697532

E-mail: tstsales@mail.taisaw.com Web: www.taisaw.com

8.000MHz Crystal Resonator

MODEL NO.: TZ0696A

REV. NO.: 1.0

Electrical Specifications:

RoHS Compliant
Lead free
Lead-free soldering

	Specification
Nominal Frequency	8.000 MHz
Mode of Vibration	Fundamental
Storage Temperature Range	-40°C to +85°C
Operating Temperature Range	-20°C to +70°C
Frequency Stability over Operating Temperature	+/-30 ppm
Frequency Make Tolerance	+/-20 ppm @ 25°C +/- 3°C
Max. Value of the Series Resistor	80Ω max.
Drive Level	100uW nominal
Load Capacitance-CL	20 pF
Aging	+/-3.0 ppm/year @25°C
Marking	Laser marking
Insulation Resistance	500M Ω min at DC 100V

Mechanical Dimensions (mm):	Marking:
	<div style="border: 1px solid black; border-radius: 15px; padding: 10px; text-align: center; width: fit-content; margin: 0 auto;"> <p>8.0000 696 T ZD</p> </div> <p>“Z” stand for product code and “D” for date code</p>

PACKING:

1. REEL DIMENSION (Unit: mm)

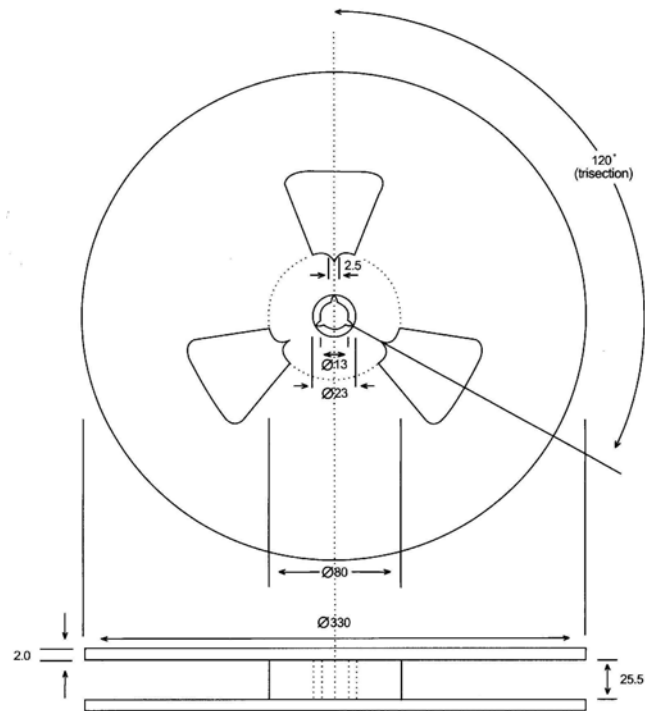

2. TAPE DIMENSION (Unit: mm)

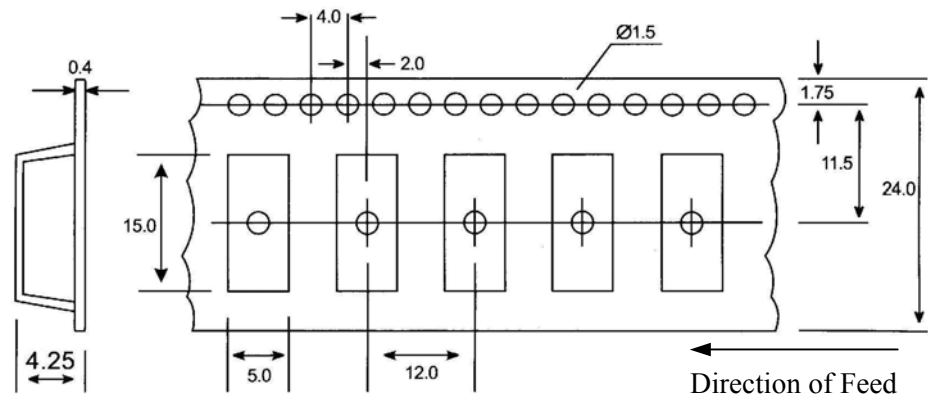

3. PACKING DIRECTION

The dot or the logo of marking should be close to the hole of tape.

Product Code Table

Year	2001 2005	2002 2006	2003 2007	2004 2008
Product Code	Z	z	<u>Z</u>	<u>z</u>

Date Code Table

WK01	WK02	WK03	WK04	WK05	WK06	WK07	WK08	WK09	WK10	WK11	WK12	WK13
A	B	C	D	E	F	G	H	I	J	K	L	M
WK14	WK15	WK16	WK17	WK18	WK19	WK20	WK21	WK22	WK23	WK24	WK25	WK26
N	O	P	Q	R	S	T	U	V	W	X	Y	Z
WK27	WK28	WK29	WK30	WK31	WK32	WK33	WK34	WK35	WK36	WK37	WK38	WK39
a	b	c	d	e	f	g	h	i	j	k	l	m
WK40	WK41	WK42	WK43	WK44	WK45	WK46	WK47	WK48	WK49	WK50	WK51	WK52
n	o	p	q	r	s	t	u	v	w	x	y	z